

GB MAFF is a new, modern line of batteries produced by a well-known European battery manufacturer ZAP Sznajder Batterien S.A., which has been producing lead acid batteries since 1925. Years of experience and continuous investments guarantee the high quality of factory products, which are present in almost every country in Europe as well as in countries of neighbouring continents.

The export grows year by year and now the batteries of **ZAP Sznajder Batterien S.A.** are being sold in more than 50 countries of the world.

F MAFF est une nouvelle gamme de batteries modernes, produites par le fabricant européen renommé ZAP Sznajder Batterien S.A., qui produit des batteries au plomb depuis 1925. Des années d'expérience et un investissement continu garantissent la haute qualité des produits d'usine qui sont présents dans presque tous les pays d'Europe ainsi que dans les pays des continents voisins. L'exportation s'est développée au fil des années et, à présent, les batteries de **ZAP Sznajder Batterien S.A.** sont en vente dans plus de 50 pays du monde.

ES MAFF es una nueva y moderna línea de baterías, fabricadas por **ZAP Sznajder Batterien S.A.**, famoso productor europeo de baterías de plomo que inició su actividad en 1925. Años de experiencia e inversiones continuas, garantizan la alta calidad de los productos de la fábrica, que están presentes en casi todos los países de Europa al igual que en países de continentes cercanos.

La expansión comercial a nivel internacional crece año tras año y ahora las baterías MAFF se venden en más de 50 países de todo el mundo.

Batteries of MAFF brand have been grouped into three main lines.

Il existe trois catégories de batteries MAFF :

Las Baterías MAFF se agrupan en 3 categorías:

MAFF European line – maintenance free batteries produced in modern Calcium-Calcium expanded metal technology offered in many sizes and capacities to meet the demand of almost all cars produced in Europe.



La gamme européenne MAFF – batteries sans entretien produites à la technologie Calcium-Calcium, disponibles en différentes tailles et capacités, appropriées à presque tous les modèles de voitures fabriquées en Europe.

MAFF Línea Europea- baterías sin mantenimiento fabricadas con la tecnología Calcio-Calcio, disponibles en diferentes tamaños y capacidades, apropiadas para todos los modelos de coches fabricados en Europa.

MAFF Japan line – batteries produced for cars of Japan or Korean origin, offered in most popular capacities and sizes: 35Ah, 40Ah, 45Ah, 60Ah, 70Ah and 100Ah. Modern design, ergonomic handle and high quality will be the right choice for your Toyota, Kia or Mitsubishi. All Japan line batteries are maintenance free and produced in Calcium-Calcium technology.



La gamme japonaise MAFF – batteries produites pour les voitures japonaises et coréennes, disponibles dans les tailles et capacités les plus courantes : 35Ah, 40Ah, 45Ah, 60Ah, 70Ah et 100Ah. Design moderne et haute qualité – le choix idéal pour votre Toyota, Kia ou Mitsubishi. Tous les batteries de gamme japonaise sont sans entretien et produites à la technologie Calcium-Calcium.











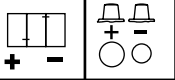



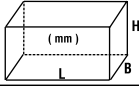

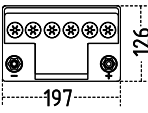
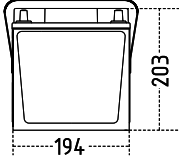
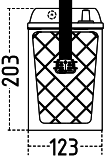

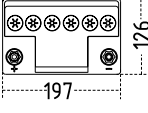
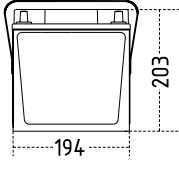
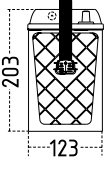

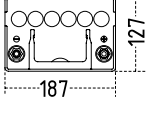
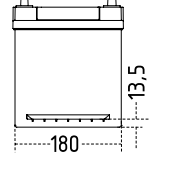
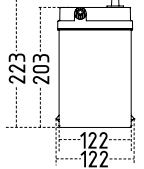

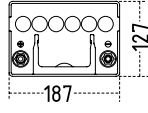
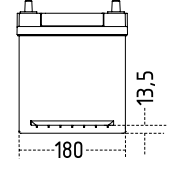
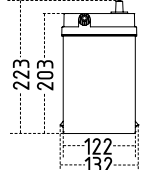

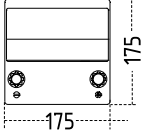
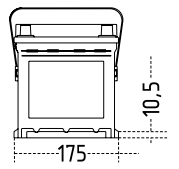
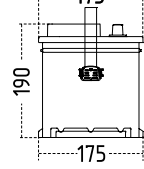
MAFF Línea Japonesa- baterías hechas para los vehículos japoneses y coreanos, disponibles en los tamaños y capacidades más demandados: 35Ah, 40Ah, 45Ah, 60Ah, 70Ah y 100Ah. Su moderno diseño, alta calidad y agarre ergonómico las convierten en tu mejor elección para tu Toyota, Kia o Mitsubishi. Todas las baterías de la Línea Japonesa son sin mantenimiento y están fabricadas con la tecnología Calcio-Calcio.

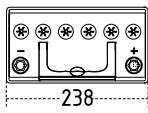
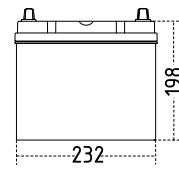
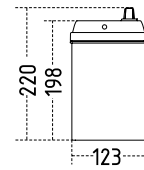

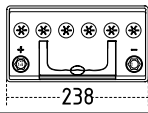
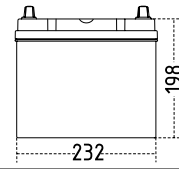
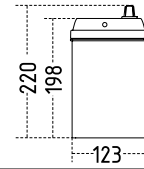
MAFF Truck line – reliable batteries for heavy duty usage in trucks and busses. High quality and dependability will let you run thousands of kilometers without any problems. Batteries produced in most common sizes and capacities up to 230Ah.

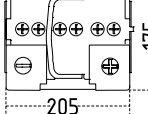
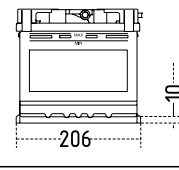
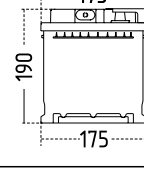

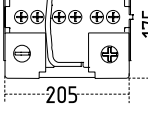
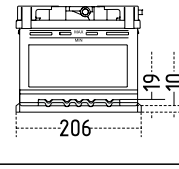
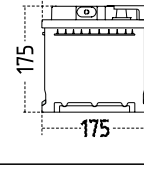

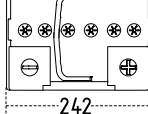
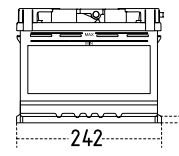
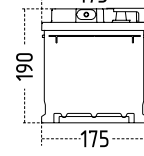

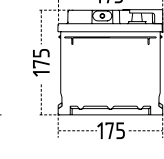

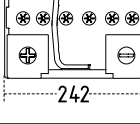
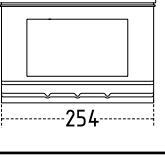







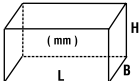

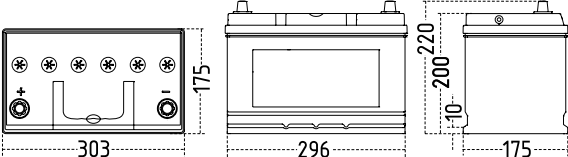

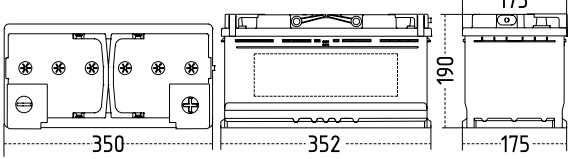

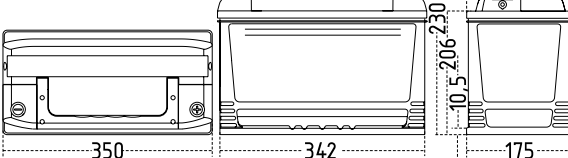

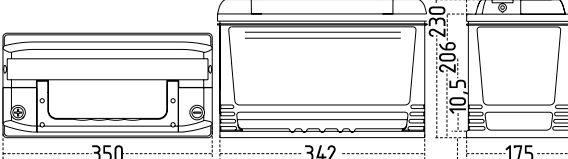

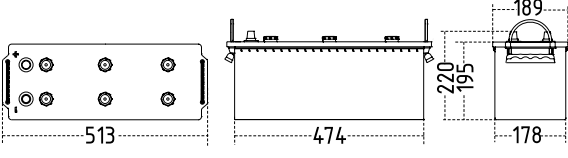
La gamme camion MAF – batteries pour camions et bus. Leur haute qualité et leur fiabilité vous permettront de rouler des milliers de kilomètres sans aucun problème. Batteries produites dans les tailles et capacités les plus courantes, jusqu' à 230 Ah.

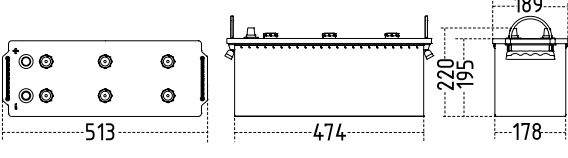

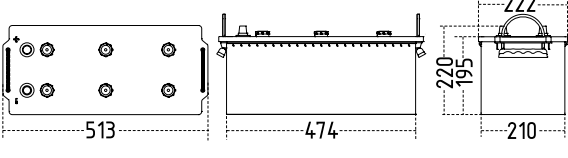

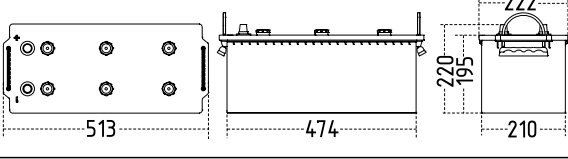

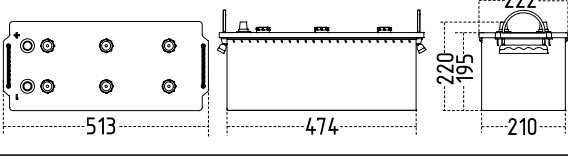
MAFF Línea de Camión- Baterías para Camión y Autobús. Su alta calidad y fiabilidad le permitirán realizar miles de kilómetros sin ningún problema. Esta línea fabrica Baterías en los tamaños y capacidades más comunes hasta 230Ah.

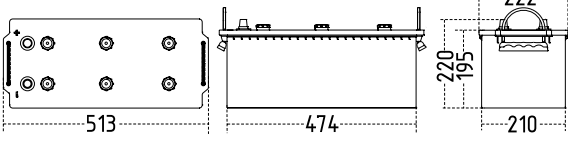
	Ah 20h	A EN							
	535 20 <i>MAFF Japan line</i>								
	35	280	0	3	B00	B20			
	535 22 <i>MAFF Japan line</i>								
	35	280	1	3	B00	B20			
	540 77 <i>MAFF Japan line</i>								
	40	330	0	3	BA1	B19			
	540 79 <i>MAFF Japan line</i>								
	40	330	1	3	BA1	B19			
	543 80 <i>MAFF European line</i>								
	43	340	0	1	B03	L0			
	545 23 <i>MAFF Japan line</i>								
	45	340	0	3+A	B00	B24			
	545 24 <i>MAFF Japan line</i>								
	45	340	1	3+A	B00	B24			
	545 80 <i>MAFF European line</i>								
	45	360	0	1	B13	L1			
	545 88 <i>MAFF European line</i>								
	45	360	0	1	B13+A	LB1			
	555 80 <i>MAFF European line</i>								
	55	460	0	1	B13	L2			

	Ah 20h	A EN					
	560 68 <i>MAFF Japan line</i>						  
60	460	0	1	B00	D23		
	560 69 <i>MAFF Japan line</i>						  
60	460	1	1	B00	D23		
	560 80 <i>MAFF European line</i>						  
60	520	0	1	B13	L2		
	560 88 <i>MAFF European line</i>						  
60	520	0	1	B13+A	LB2		
	562 80 <i>MAFF European line</i>						  
62	520	0	1	B13	L2		
	565 80 <i>MAFF European line</i>						  
65	540	0	1	B13	L2		
	565 81 <i>MAFF European line</i>						  
65	540	1	1	B13	L2		
	570 24 <i>MAFF Japan line</i>						  
70	540	1	1	B05	D26		
	570 29 <i>MAFF Japan line</i>						  
70	540	0	1	B05	D26		
	570 80 <i>MAFF European line</i>						  
70	600	0	1	B13	L3		

	Ah 20h	A EN					
	570 88 MAFF European line						
70	610	0	1	B13+A	LB3		
	572 88 MAFF European line						
72	640	0	1	B13+A	LB3		
	574 80 MAFF European line						
74	680	0	1	B13	L3		
	575 80 MAFF European line						
75	720	0	1	B13	L3		
	575 81 MAFF European line						
75	720	1	1	B13	L3		
	575 88 MAFF European line						
75	680	0	1	B13+A	LB3		
	580 88 MAFF European line						
80	700	0	1	B13+A	LB4		
	585 42 MAFF European line						
85	700	0	1	B13	L4		
	592 80 MAFF European line						
92	720	0	1	B13	L5		
	600 32 MAFF Japan line						
100	680	0	1	B01	D31		

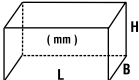
	Ah 20h	A EN					
	600 33 <i>MAFF Japan line</i>						
	600 80 <i>MAFF European line</i>						
	625 11 <i>MAFF Truck line</i>						
	625 12 <i>MAFF Truck line</i>						
	625 13 <i>MAFF Truck line</i>						
	645 20 <i>MAFF Truck line</i>						
	670 14 <i>MAFF Truck line</i>						
	680 14 <i>MAFF Truck line</i>						
	690 14 <i>MAFF Truck line</i>						
	700 14 <i>MAFF Truck line</i>						

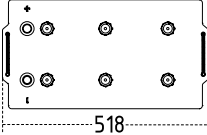
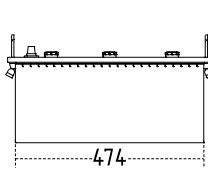
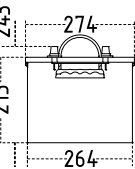
	Ah 20h	A EN					
	730 11	MAFF Truck line					
	230	1200	1	3	B00	D6	  

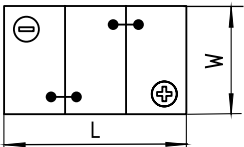
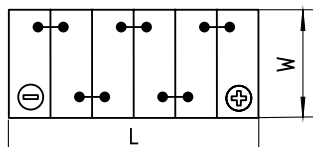
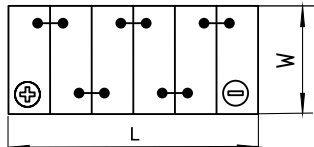
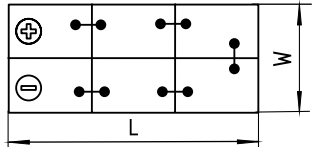
Layouts / Polarité			
6V		12V	
0		0	
			
1		3	
			

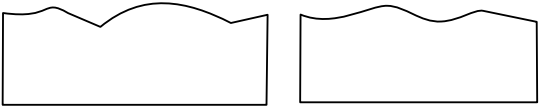
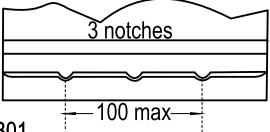
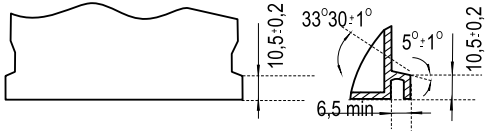
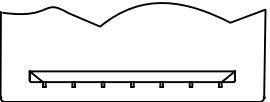
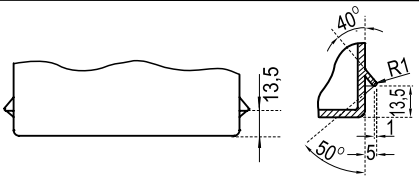
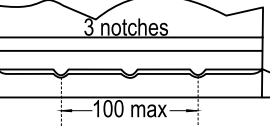
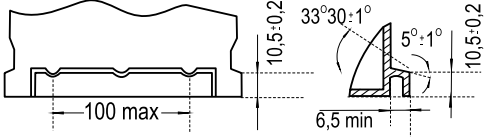
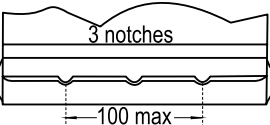
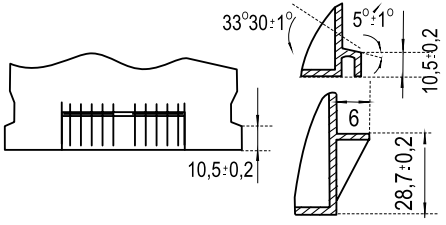
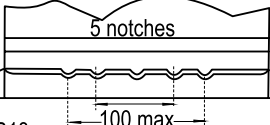
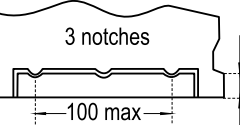
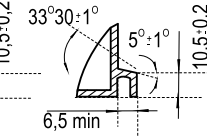
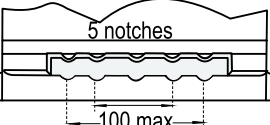
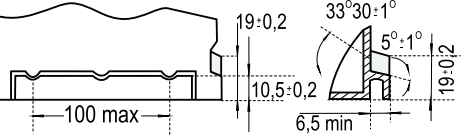
Base Hold-downs / Fixation	
B00	
B01	 
BA1	 
B03	 
B05	 
B13	  
B13 + A	 

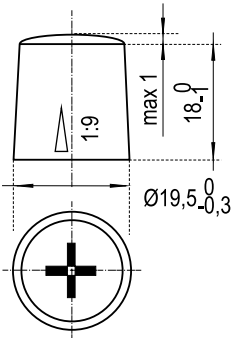
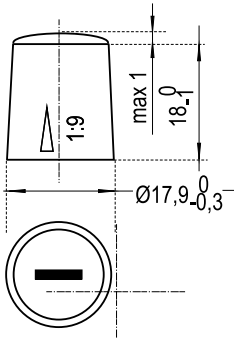
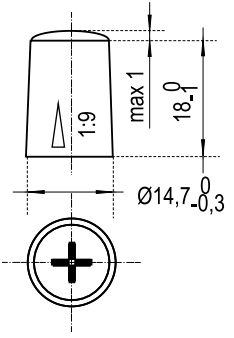
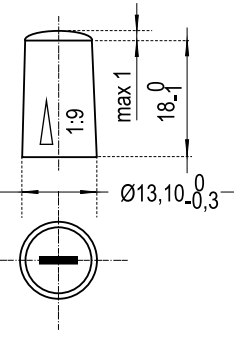
Terminals/ Polo Bornes	
1	 
3	 
3+A	